



특징 (Character)

- 센서 사용이 가능한 WEDGE방식 회전용 AIR FINGER
Air finger for rotation wedge type which available to use sensor
- AF56N SERIES에 회전 장치 부착으로 연속 회전이 가능
Possible to continuous rotation by attaching turning gear to AF56N SERIES
- 허용회전수 - 100 회/분
Admissible RPM is 100
- 회전중에도 마그네틱 센서에 의한 개,폐 검출이 가능
It is available for open-close sensing by magnetic sensor during rotation.
- 타이밍벨트 - XL037-32NT, XL037-40NT사용
Timing belt



연속회전용 테이퍼 슬라이딩 방식의 3JAW (Wedge type 3 jaw rotation gripper)

정밀한 T형 가이드 (Precise T-slot guide)

높은 힘과 고강성
high force and moment
absorption

몸체 (Body)

경질 처리된 경량의
알루미늄 합금
high-tensile aluminum body with
lightest possible because of
hard anodizing

회전구동 (Driving)

타이밍 풀리
timing pulley

작동 방식 (Kinetic)

큰힘의 중심 파지를 위한
테이퍼 슬라이딩 방식
wedge system for high level of power
transmission and centric gripping

조 (Jaws)

파지부
for gripping

구동부 (Drive)

복동식
double acting
pneumatic cylinder

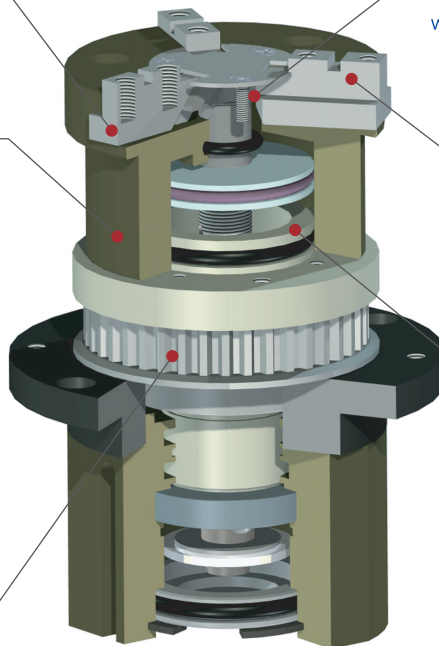

부품분해도 (Exploded view)

※ 본 분해도는 한 제품을 예시하였으므로 기종별로 차이가 있을 수 있습니다.
 ※ This is exploded view illustrates a certain product only. The contents may vary by product models.

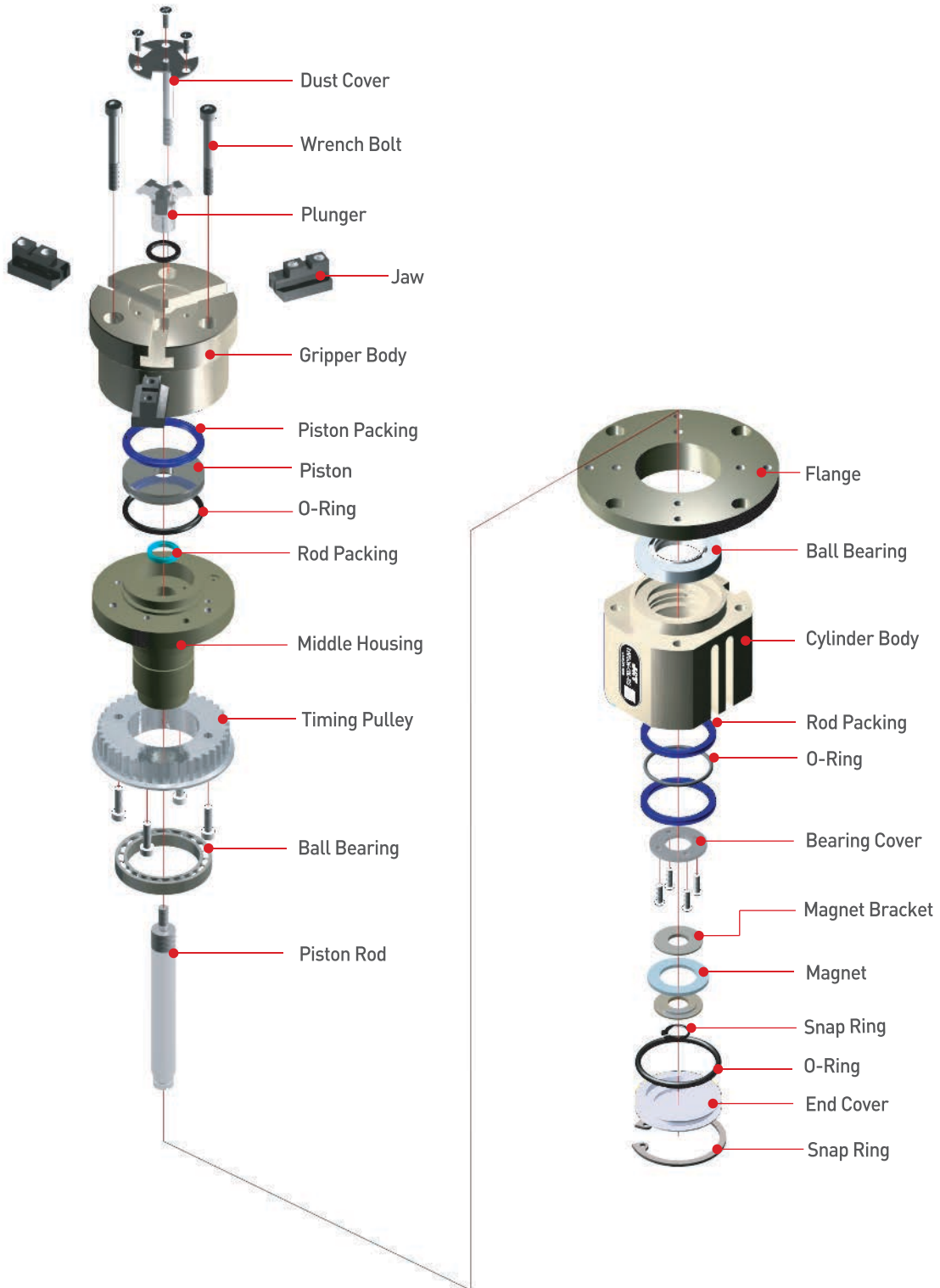

AF101
AF02
AF04P
AF105P
AF10
AF13
AF14
AF15
AF316
AF316L
AF416
AF17
AF117
AF24
AF26
AF28D
AF28DS
AF30 (SN)
AF30L
AF46 (SN)
AF56L
RAF56N
MF16

주문기호 (How to Order)

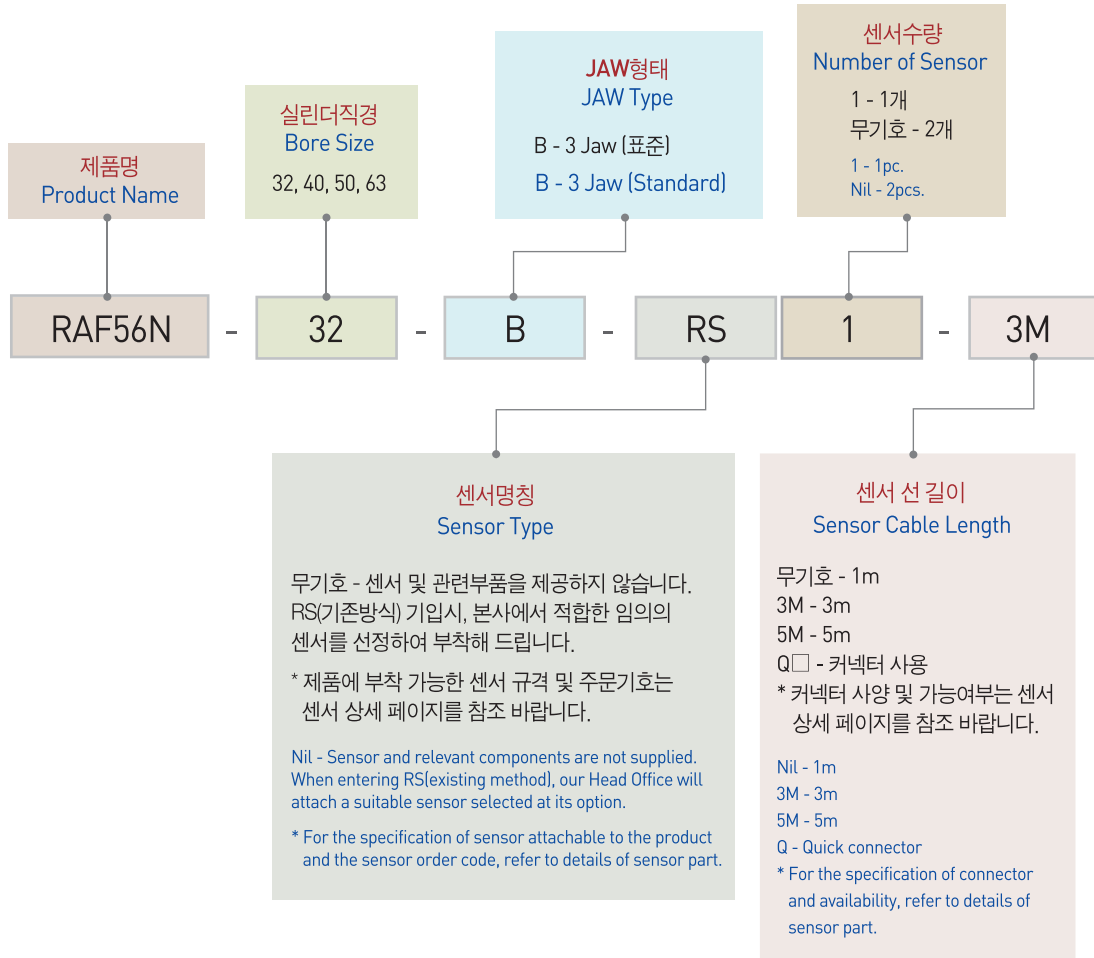

☐ 제품사양 (Specification)

P=공기압력(bar), L=작용점까지의 거리(mm)
P = Air Pressure(bar), L = Gripping point distance(mm)

제품명칭 Products Name	RAF56N-32-B	RAF56N-40-B	RAF56N-50-B	RAF56N-63-B	단위 Unit
개폐범위 Stroke	8	10	12	16	mm
제품중량 Weight	0.95	1.43	1.74	2.40	kg
최대치구길이 Max. length attach	50	60	80	100	mm
배관접속구 Fitting size	M5	M5	M5	M5	
파지력 : 열림시 Gripping force : Open	56.90P/[(1+0.009L)]	103.99P/[(1+0.007L)]	150.09P/[(1+0.007L)]	238.38P/[(1+0.006L)]	N
파지력 : 닫힘시 Gripping force : Close	52.97P/[(1+0.009L)]	95.16P/[(1+0.007L)]	138.32P/[(1+0.007L)]	211.90P/[(1+0.006L)]	N
타이밍풀리 Timing Pulley Specification	XL037-32NT	XL037-40NT	XL037-40NT	XL037-40NT	
부하토크 (공기압력:0~5 bar) Load Torque (Air Pressure:0~5 bar)	0.3 ~ 0.9	0.5 ~ 2.5	0.5 ~ 2.5	0.4 ~ 2.8	N·m
1사이클당 공기소모량 Air consumption per cycle	6.8	14.9	27.9	59.7	cm ³
닫힘시/열림시 시간 Closing / Opening time	0.01/0.01	0.02/0.02	0.03/0.03	0.06/0.06	sec
반복정밀도 Repeat accuracy	0.01	0.01	0.01	0.01	mm
연속사용회수 Continuation usage amount	60	50	50	50	cpm
허용회전수 Revolution per minute	100	100	100	100	rpm
사용압력 Operating pressure	3~7				bar
주위온도 Ambient temperature	-5 to 60				°C
윤활 Lubrication	불필요 Needless				

반복정밀도 : 연속 100회 작동후 측정치
After 100 consecutive strokes to end positions

AF101

AF02

AF04P

AF105P

AF10

AF13

AF14

AF15

AF316

AF316L

AF416

AF17

AF117

AF24

AF26

AF28D

AF28DS

AF30 (SN)

AF30L

AF46 (SN)

AF56L

RAF56N

MF16

RAF56N-32-B

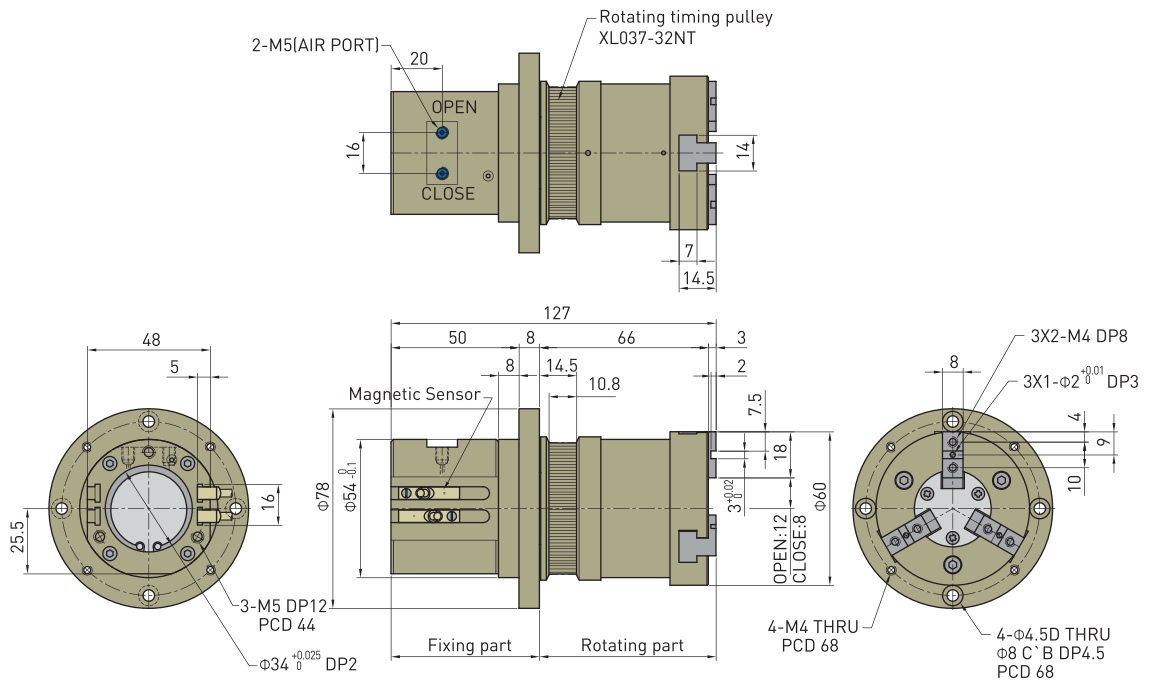

RAF56N-40-B

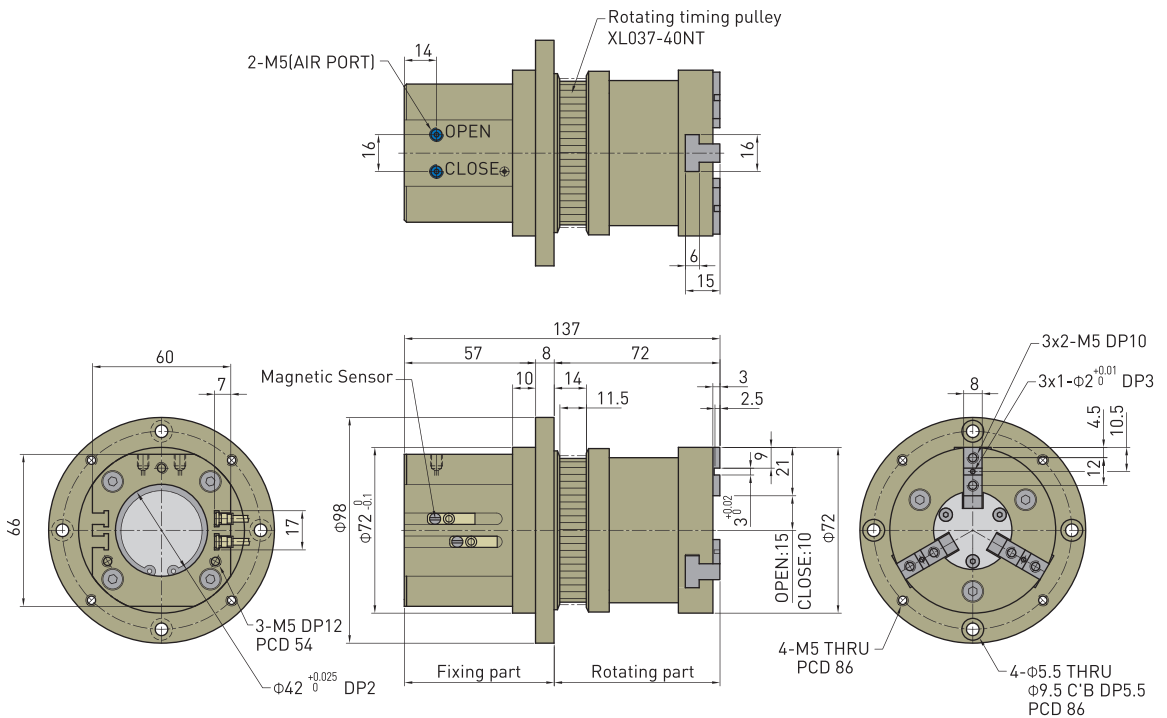

RAF56N-50-B

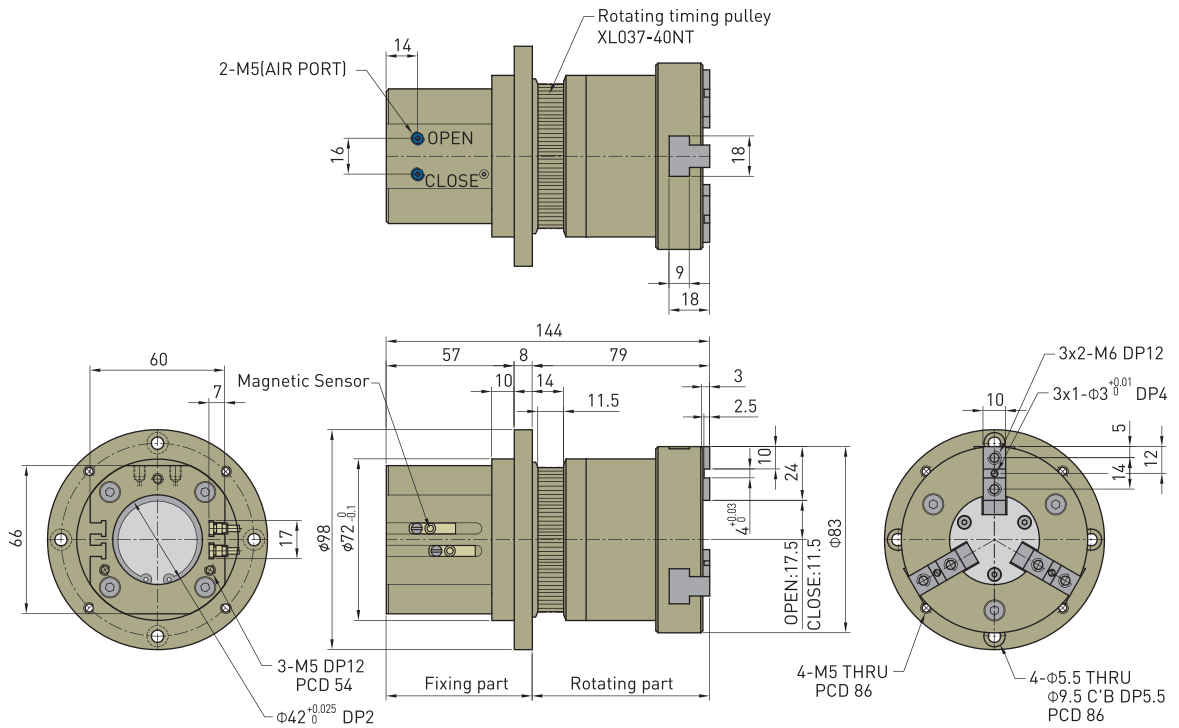

RAF56N-63-B

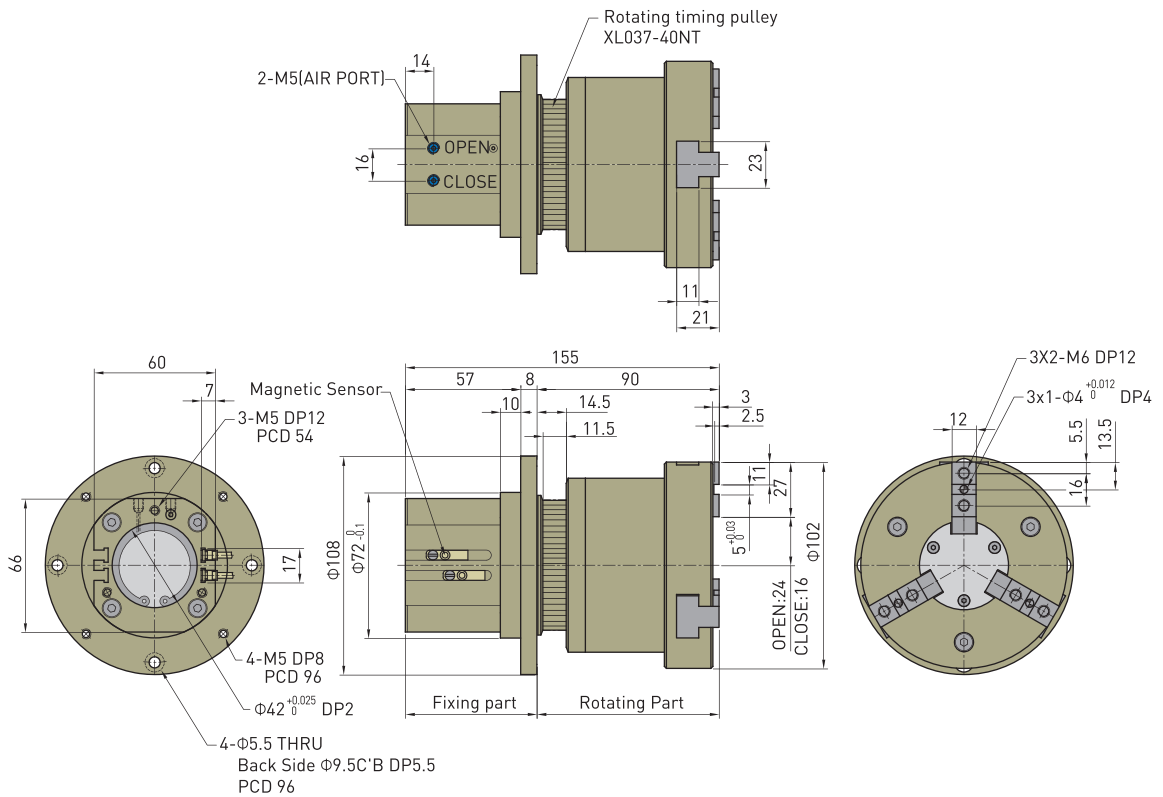

AF101

AF02

AF04P

AF105P

AF10

AF13

AF14

AF15

AF316

AF316L

AF416

AF17

AF117

AF24

AF26

AF28D

AF28DS

AF30(SN)

AF30L

AF46(SN)

AF56L

RAF56N

MF16