



## 특징 ( Character )

- RACK & PINION을 사용한 광각형 각도개폐방식  
Angular type by Rack & Pinion driving unit
- 개폐범위가 180도로 제품 파지시 간섭배제가 가능  
Allow to grip the workpiece by open-close range 180° without any interference
- 개폐검출 센서 전기종 부착가능  
Magnetic sensor is available for open-close sensing



## 랙 & 피니언 방식 ( Rack & pinion type )

### 작동 방식 ( Kinetics )

랙 & 피니언 방식  
pinion and toothed rack  
system, centric gripping

### 조 ( Jaws )

파지부  
for gripping

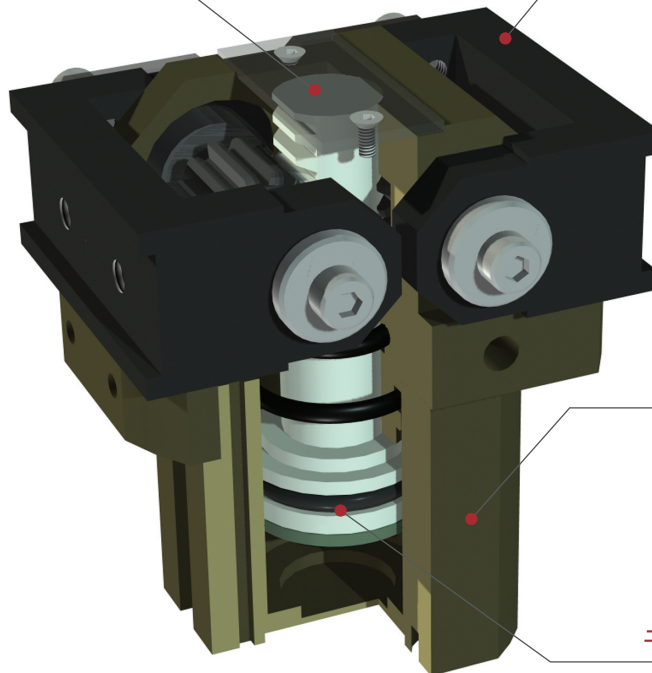

### 몸체 ( Body )

경질 처리된 경량의  
알루미늄 합금  
aluminum body with  
st possible because of  
hard anodizing

### 구동부 ( Drive )

복동식  
double acting  
pneumatic cylinder

부품분해도 (Exploded view)

※ 본 분해도는 한 제품을 예시하였으므로 기종별로 차이가 있을 수 있습니다  
 ※ This exploded view illustrates a certain product only. The contents may vary by product models.

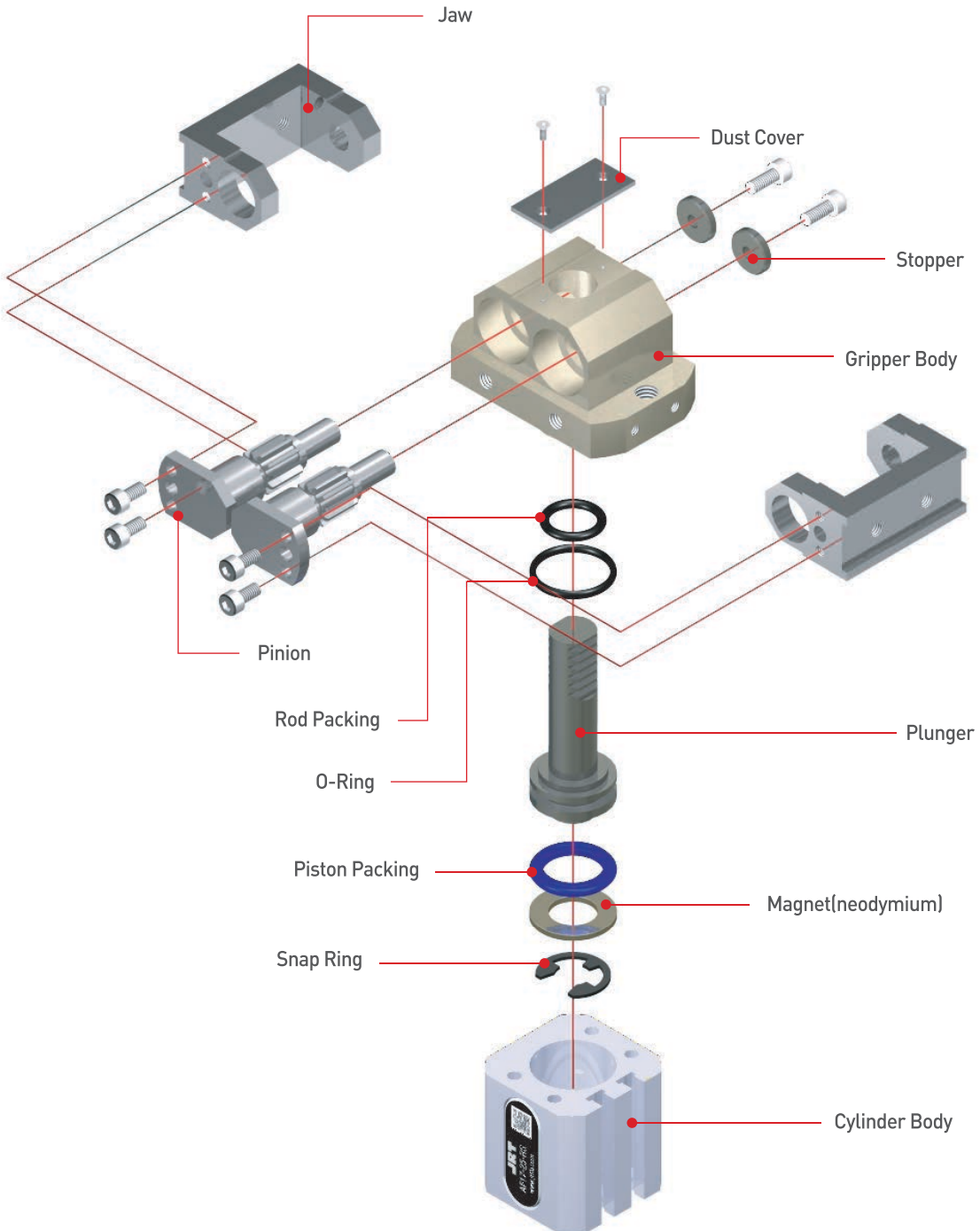

AF101

AF02

AF04P

AF105P

AF10

AF13

AF14

AF15

AF316

AF316L

AF416

**AF17**

AF117

AF24

AF26

AF28D

AF28DS

AF30 (SN)

AF30L

AF46 (SN)

AF56L

RAF56N

MF16

주문기호 ( How to Order )

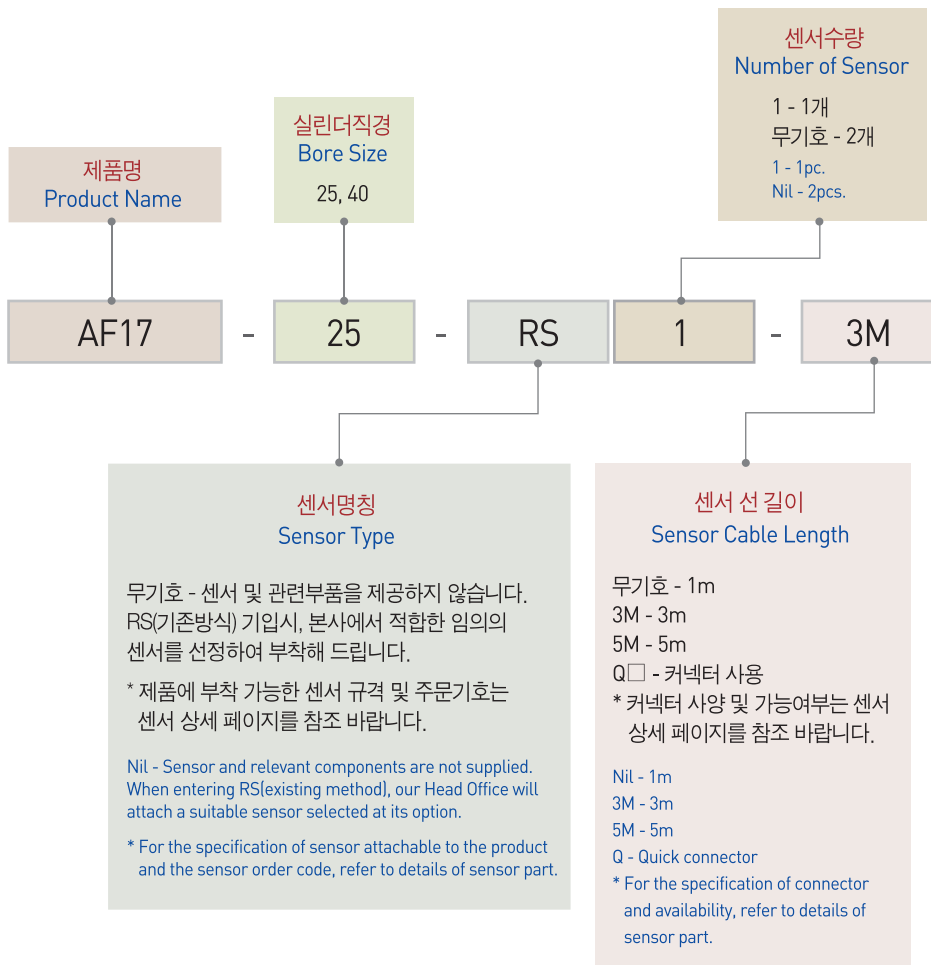

## ☐ 제품사양 ( Specification )

P=공기압력(bar), L=작용점까지의 거리(mm)  
P = Air Pressure(bar), L = Gripping point distance(mm)

제품명칭 Products Name	AF17-25	AF17-40	단위 Unit
개폐범위 Stroke	0 to 180	0 to 180	degree
제품중량 Weight	0.68	0.86	kg
최대치구길이 Max. length attach	50	50	mm
배관접속구 Fitting size	M5	PF(G) 1/8	
파지력 : 열림시 Gripping force : Open	22.56P/0.1L	51.01P/0.1L	N
파지력 : 닫힘시 Gripping force : Close	15.70P/0.1L	38.26P/0.1L	N
1사이클당 공기소모량 Air consumption per cycle	8.3	21.2	cm <sup>3</sup>
닫힘시/열림시 시간 Closing / Opening time	0.01/0.01	0.01/0.02	sec
반복정밀도 Repeat accuracy	0.2	0.2	mm
연속사용회수 Continuation usage amount	60	60	cpm
사용압력 Operating pressure	3~7		bar
주위온도 Ambient temperature	-5 to 60		°C
윤활 Lubrication	불필요 Needless		

반복정밀도 : 연속 100회 작동후 측정치  
After 100 consecutive strokes to end positions

## ☐ 작용점에서의 파지력 ( Gripping Force From a Point of Action )

범례( Legend ) : —■ 7[bar] —■ 5[bar] —■ 3[bar]

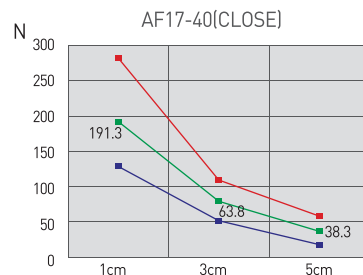
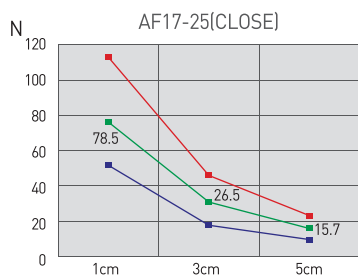
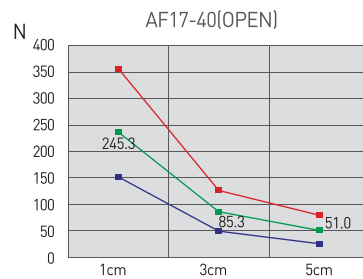
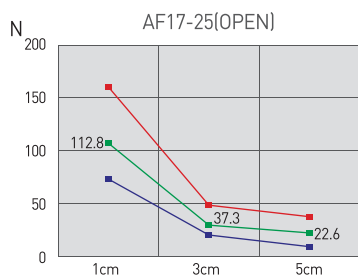

AF101

AF02

AF04P

AF105P

AF10

AF13

AF14

AF15

AF316

AF316L

AF416

**AF17**

AF117

AF24

AF26

AF28D

AF28DS

AF30 (SN)

AF30L

AF46 (SN)

AF56L

RAF56N

MF16

AF17-25

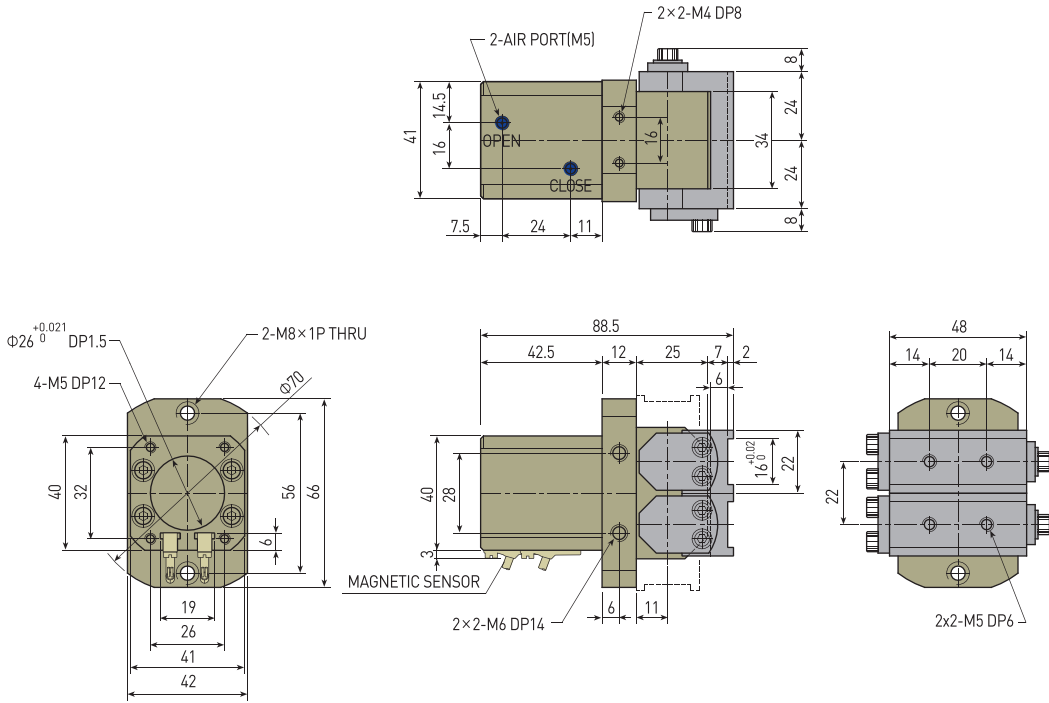

AF17-40

