

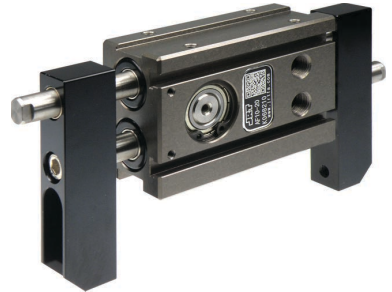

## 특징 (Character)

- RACK & PINION에 의한 광폭형 개폐방식  
Rack & pinion type
- SLIM TYPE BODY의 횡형 개폐방식으로 광범위한 제품파지에 적합한 구조  
Suitable structure for extensive gripping work by slim type body`s horizontal opening type
- 개폐검출 센서 전기종 부착가능  
Magnetic sensor is available for open-close sensing
  - ▶ AF10 TYPE은 닫힐때 가이드 로드가 돌출됩니다.
  - ▶ Guide rod protrudes when AF10 type is closed



## 랙 & 피니언 방식 (Rack & Pinion type)

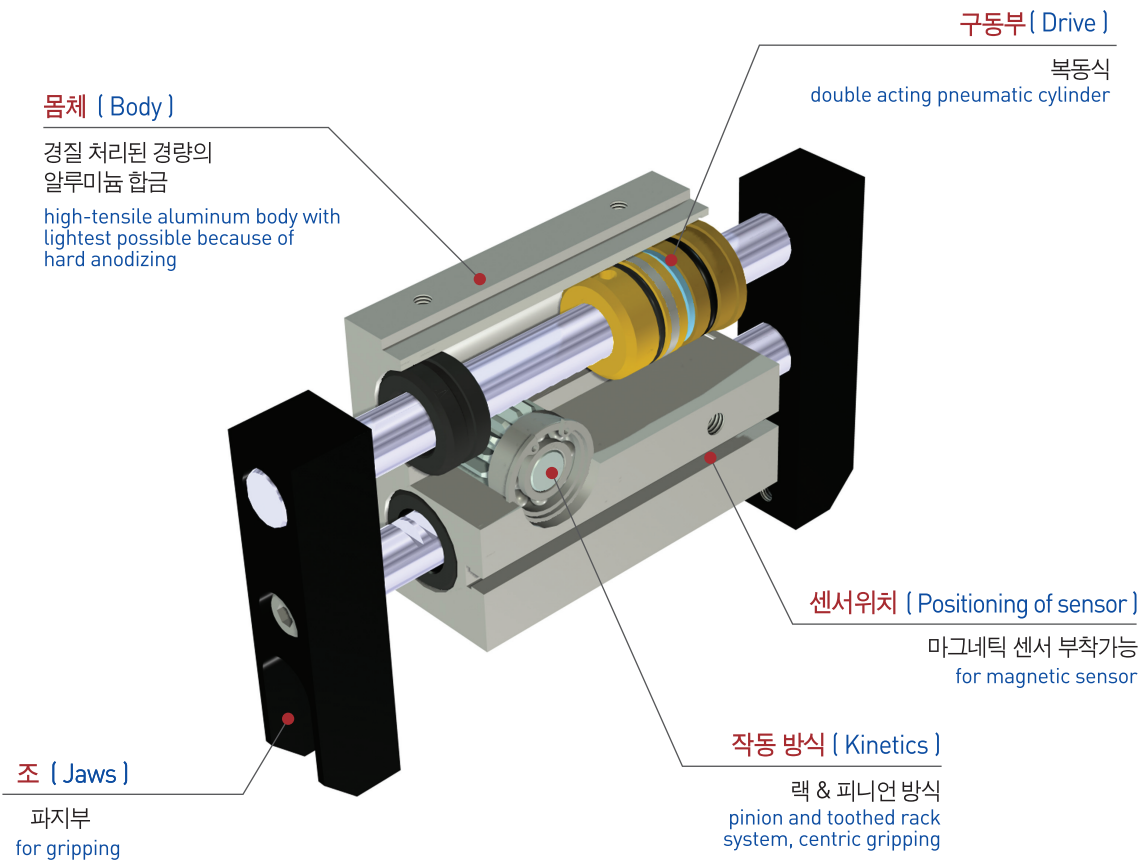

- AF101
- AF02
- AF04P
- AF105P
- AF10**
- AF13
- AF14
- AF15
- AF316
- AF316L
- AF416
- AF17
- AF117
- AF24
- AF26
- AF28D
- AF28DS
- AF30 (SN)
- AF30L
- AF46 (SN)
- AF56L
- RAF56N
- MF16

부품분해도 ( Exploded view )

※ 본 분해도는 한 제품을 예시하였으므로 기종별로 차이가 있을 수 있습니다  
 ※ This exploded view illustrates a certain product only. The contents may vary by product models.

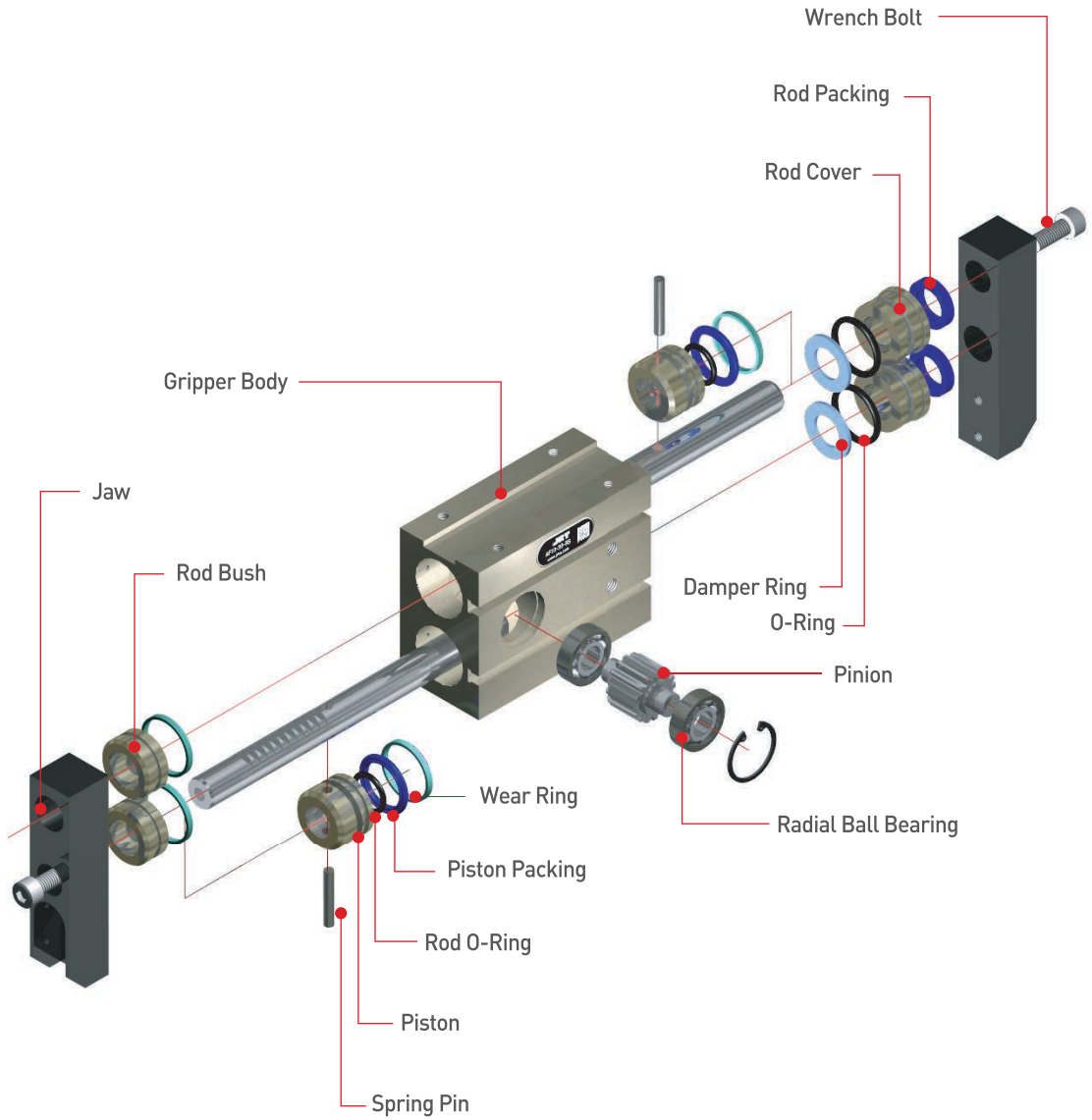

주문기호 ( How to Order )

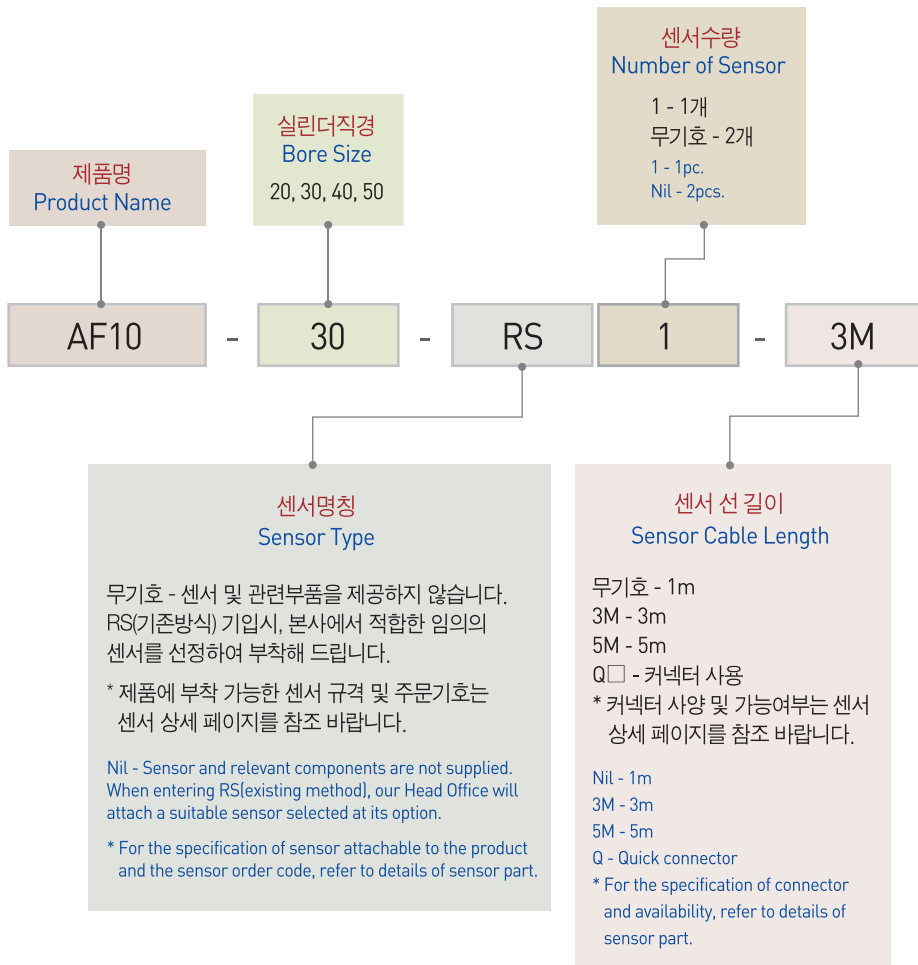
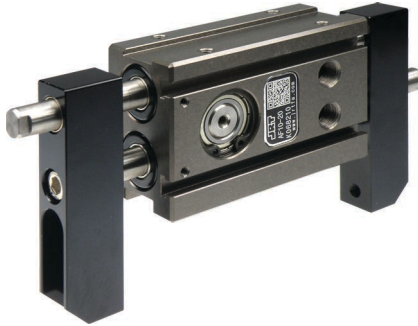

- AF101
- AF02
- AF04P
- AF105P
- AF10
- AF13
- AF14
- AF15
- AF316
- AF316L
- AF416
- AF17
- AF117
- AF24
- AF26
- AF28D
- AF28DS
- AF30 (SN)
- AF30L
- AF46 (SN)
- AF56L
- RAF56N
- MF16

## ▣ 제품사양 ( Specification )

P=공기압력(bar), L=작용점까지의 거리(mm)  
P = Air Pressure(bar), L = Gripping point distance(mm)

| 제품명칭<br>Products Name                    | AF10-20           | AF10-30           | AF10-40          | AF10-50           | 단위<br>Unit      |
|--|-------------------|-------------------|------------------|-------------------|-----------------|
| 개폐범위<br>Stroke                           | 30                | 40                | 60               | 100               | mm              |
| 제품중량<br>Weight                           | 0.67              | 1.9               | 4.6              | 9.22              | kg              |
| 최대치구길이<br>Max. length attach             | 60                | 85                | 120              | 160               | mm              |
| 배관접속구<br>Fitting size                    | PF(G) 1/8         | PF(G) 1/8         | PF(G) 1/8        | PF(G) 1/8         |                 |
| 파지력 : 열림시<br>Gripping force : Open       | 11.48P/(1+0.015L) | 25.02P/(1+0.015L) | 41.2P/(1+0.015L) | 63.77P/(1+0.015L) | N               |
| 파지력 : 닫힘시<br>Gripping force : Close      | 11.48P/(1+0.015L) | 25.02P/(1+0.015L) | 41.2P/(1+0.015L) | 63.77P/(1+0.015L) | N               |
| 1사이클당 공기소모량<br>Air consumption per cycle | 8.2               | 24.3              | 66.0             | 171.8             | cm <sup>3</sup> |
| 닫힘시/열림시 시간<br>Closing / Opening time     | 0.01/0.01         | 0.01/0.01         | 0.03/0.03        | 0.09/0.09         | sec             |
| 반복정밀도<br>Repeat accuracy                 |                   |                   |                  |                   | 0.1             |
| 연속사용회수<br>Continuation usage amount      |                   |                   |                  |                   | 60              |
| 사용압력<br>Operating pressure               |                   |                   |                  |                   | 3~7             |
| 주위온도<br>Ambient temperature              |                   |                   |                  |                   | -5 to 60        |
| 윤활<br>Lubrication                        |                   |                   |                  |                   | 불필요<br>Needless |

반복정밀도 : 연속 100회 작동후 측정치  
After 100 consecutive strokes to end positions

## ▣ 작용점에서의 파지력 ( Gripping Force From a Point of Action )

범례( Legend ) : —■— 7[bar] —■— 5[bar] —■— 3[bar]

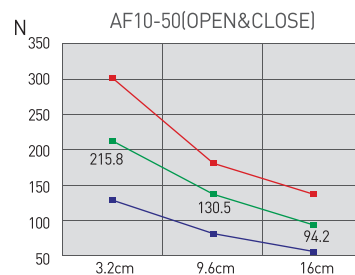
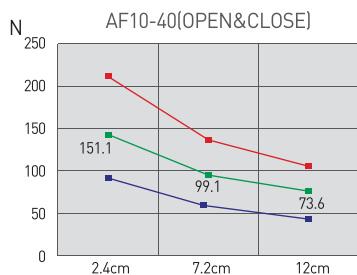
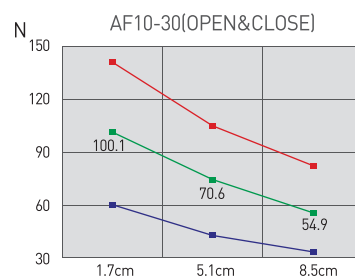
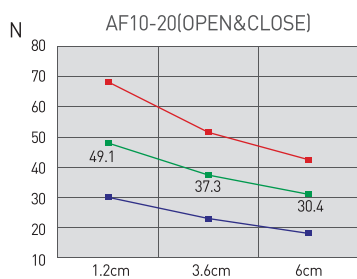

AF10-20

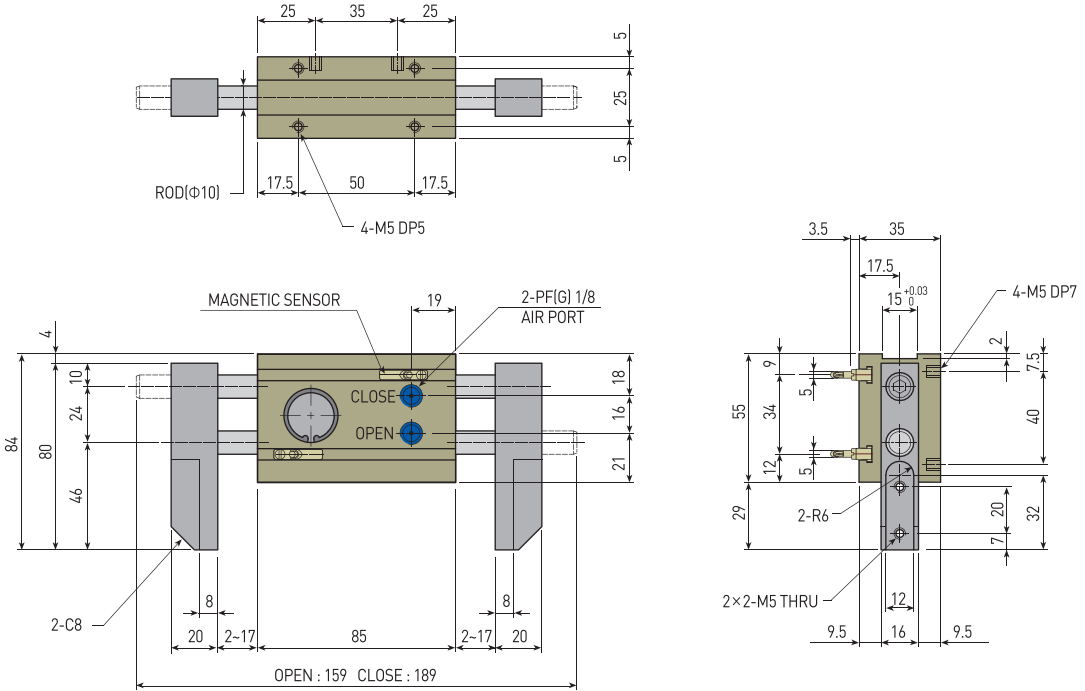

AF10-30

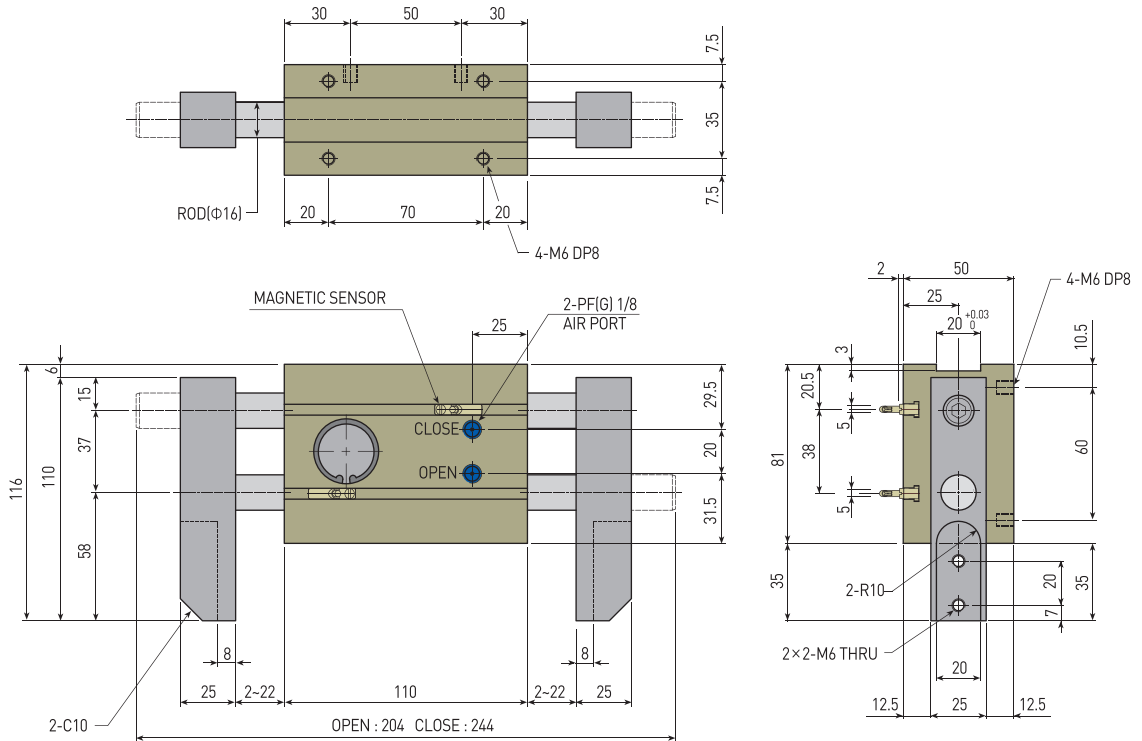

AF101

AF02

AF04P

AF105P

AF10

AF13

AF14

AF15

AF316

AF316L

AF416

AF17

AF117

AF24

AF26

AF28D

AF28DS

AF30 (SN)

AF30L

AF46 (SN)

AF56L

RAF56N

MF16

AF10-40

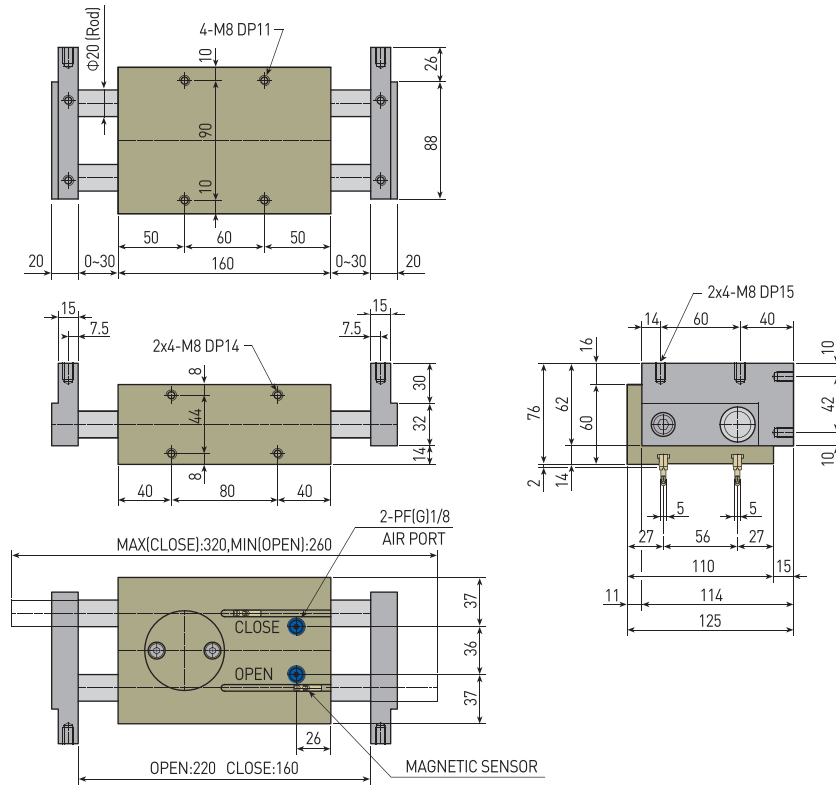

AF10-50

